



RA12-75 (12V75Ah)

RA series is a general purpose battery with 10 years design life in float service. It meets with IEC, JIS and BS standards. With up-dated AGM valve regulated technology and high purity raw materials, the RA series battery maintains high consistency for better performance and reliable standby service life. It is suitable for UPS/EPS, medical equipment, emergency light and security system applications.



Specification

Cells Per Unit	6
Voltage Per Unit	12
Capacity	75Ah@10hr-rate to 1.80V per cell @25°C
Weight	Approx. 23.5 Kg (Tolerance ±2%)
Max. Discharge Current	750A (5 sec)
Internal Resistance	Approx. 5.8 mΩ
Operating Temperature Range	Discharge: -20°C~60°C Charge: 0°C~50°C Storage: -20°C~60°C
Normal Operating Temperature Range	25°C ± 5°C
Float charging Voltage	13.6 to 13.8 VDC/unit Average at 25°C
Recommended Maximum Charging Current	22.5 A
Equalization and Cycle Service	14.6 to 14.8 VDC/unit Average at 25°C
Self Discharge	RITAR Valve Regulated Lead Acid(VRLA) batteries can be stored for more than 6 months at 25°C. Self-discharge ratio less than 3% per month at 25°C. Please charge batteries before using.
Terminal	Terminal F11/F15
Container Material	A.B.S. UL94-HB, UL94-V0 Optional.



Dimensions

Unit: mm Dimension: 260(L) × 169(W) × 235(H)

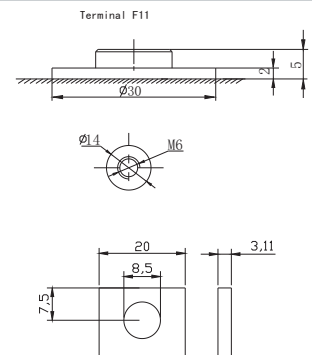
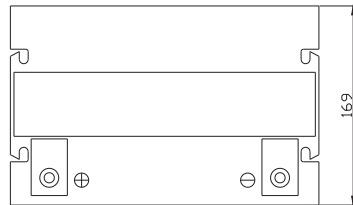
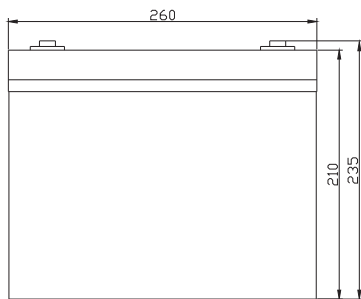

Constant Current Discharge Characteristics: A (25°C)

F.V/Time	5MIN	10MIN	15MIN	30MIN	1HR	2HR	3HR	4HR	5HR	8HR	10HR	20HR
9.60V	262.6	193.3	144.2	75.35	46.81	28.90	19.64	15.84	13.15	8.66	7.80	4.13
10.0V	255.0	184.0	141.3	74.39	46.19	28.32	19.28	15.61	13.03	8.63	7.73	4.05
10.2V	247.5	177.5	139.1	73.25	45.75	28.02	19.11	15.46	12.94	8.55	7.65	3.98
10.5V	222.2	163.8	132.4	71.23	45.19	27.65	18.94	15.23	12.84	8.47	7.58	3.90
10.8V	200.6	149.3	122.0	68.88	44.56	27.43	18.72	14.71	12.77	8.44	7.51	3.86
11.1V	171.2	133.5	109.5	66.26	43.51	26.32	18.35	14.50	12.68	8.37	7.42	3.70

Constant Power Discharge Characteristics: W(25°C)

F.V/Time	5MIN	10MIN	15MIN	30MIN	1HR	2HR	3HR	4HR	5HR	8HR	10HR	20HR
9.60V	2770	2059	1572	862.6	542.5	338.7	231.2	189.6	157.5	103.7	93.59	49.77
10.0V	2716	1996	1547	853.6	537.5	334.6	227.8	186.9	156.1	103.3	92.85	48.91
10.2V	2685	1943	1530	846.2	534.4	332.2	226.8	185.2	155.1	102.5	92.03	48.00
10.5V	2444	1810	1459	828.9	530.9	328.0	225.0	182.7	153.9	101.7	91.12	47.09
10.8V	2226	1668	1349	809.3	524.1	325.5	222.4	176.5	153.2	101.2	90.22	46.64
11.1V	1955	1508	1214	787.1	516.3	313.3	218.7	174.0	152.6	100.5	89.24	44.97

All mentioned values are average values (Tolerance ±2%).

Effect of temperature on long term float life

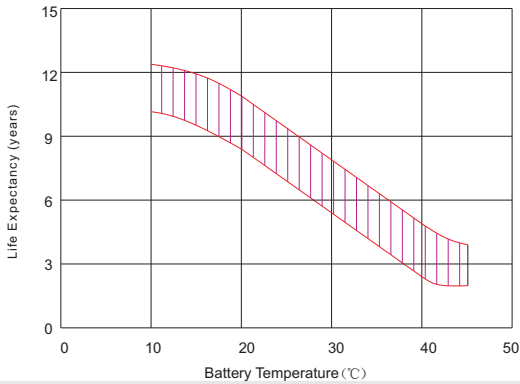

Storage characteristic

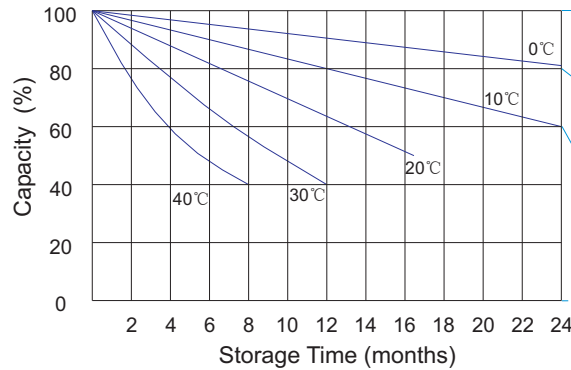

Supplementary charge required (Carry out supplementary charge before use if 100% capacity is required)

Supplementary charge required before use. This supplementary charge will help to recover the capacity and should be made as early as possible.

Supplementary charge may often fail to recover the capacity. The battery should never be left standing till this state is reached

Supplementary charge and storage guidelines

Charge characteristic Curve for standby use

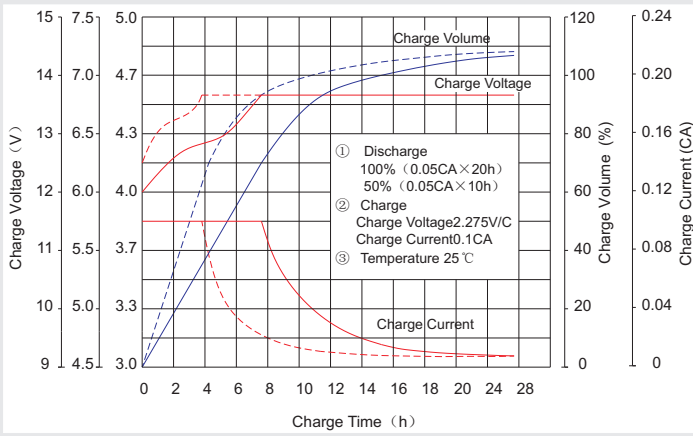

Discharge characteristic Curve

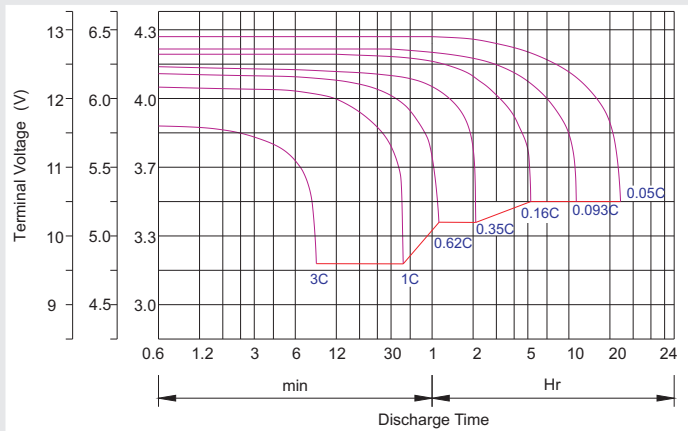

Capacity Factors With Different Temperature

Battery Type		-20°C	-10°C	0°C	5°C	10°C	20°C	25°C	30°C	40°C	45°C
Battery	6V&12V	50%	70%	83%	85%	90%	98%	100%	102%	104%	105%
	2V	60%	75%	85%	88%	92%	99%	100%	103%	105%	106%
Battery	6V&12V	46%	66%	76%	83%	90%	98%	100%	103%	107%	109%
	2V	55%	70%	80%	85%	92%	99%	100%	104%	108%	110%

Discharge Current VS. Discharge Voltage

Final Discharge Voltage V/cell	1.75V	1.70V	1.60V
Discharge Current (A)	(A) ≤ 0.2C	0.2C < (A) < 1.0C	(A) ≥ 1.0C

Charge the batteries at least once every six months, if they are stored at 25°C.

Charging Method:

Constant Voltage	-0.2Cx2h+2.4-2.45V/cellx24h, Max. Current 0.3C
Constant Current	-0.2Cx2h+0.1Cx12h
Fast	-0.2Cx2h+0.3Cx4h

Bolt	M5	M6	M8
Terminal	F3 F4 F13 F18 T25 T26	F8 F11 F12-1 F15	F5 F9 F10 F12 F14 F16
Torque	6~7N·m	8~10N·m	10~12N·m

Maintenance & Cautions

Float Service:

※ Every month, recommend inspection every battery voltage.

※ Every three months, recommend equalization charge for one time.

Equalization charge method:

Discharge: 100% rate capacity discharge.

Charge: Max. current 0.3CA, constant voltage 2.4-2.45V/Cell charge 24h.

※ Effect of temperature on float charge voltage: -3mV/°C/Cell.

※ Length of service life will be directly affected by the number of discharge cycles, depth of discharge, ambient temperature and charging voltage.